

**BUN VENIT ÎN  
CARGO-CITY**



**UȘI SECȚIONALE CARGO Novoferm Siebau**



Cunoști deja noile tipuri  
de UȘI CARGO tipurile  
CT 45 și CT 67?



# Novoferm Siebau – calitate consacrată

- 1993 Integrarea în Grupul Novoferm
- 1996 Dezvoltarea ușilor CARGO pentru suprastructurile de camioane
- 2013 Extinderea portofoliului de produse cu ușile din aluminiu
- 2018 Dezvoltarea ușii pentru compartimente frigorifice CT-67 cu protecție eficientă împotriva prinderii degetelor
- 2022/23 Dezvoltarea ușii pentru compartimente de produse proaspete CT-45 cu protecție eficientă împotriva prinderii degetelor

**Din 1996 suntem partenerul de nădejde al clienților noștri din sectorul vehiculelor utilitare.**

Ușile noastre CARGO sunt disponibile în toate variantele de vehicule și suprastructuri închise și reprezintă parte integrantă a gamei de produse oferite de numeroși producători de vehicule. Cooperarea constructivă cu clienții și cerințele specifice ale acestora construiesc baza dezvoltării continue reușite a ușilor CARGO.

 <b>LIVRARE NOCTURNĂ SILENȚIOASĂ</b>	<b>4</b>
 <b>SERVICII FARMACEUTICE</b>	<b>6</b>
 <b>MĂRFURI VALOROASE</b>	<b>8</b>
 <b>TRANSPORT SIGUR</b>	<b>8</b>
 <b>ANTI-EFRAȚIE</b>	<b>8</b>
 <b>MĂRFURI REFRIGERATE</b>	<b>10</b>
 <b>TRANSPORT MĂRFURI PROASPETE</b>	<b>10</b>
 <b>CERTIFICAT CODE XL</b>	<b>12</b>
 <b>ECO LOGIC</b>	<b>14</b>
 <b>EFICIENT ENERGETIC</b>	<b>14</b>
<b>PERSPECTIVE SIEBAU</b>	<b>16</b>
<b>INFORMAȚIA ÎNSEAMNĂ COMUNICARE</b>	<b>18</b>
<b>ÎNCREDEREA CLIENȚILOR</b>	<b>20</b>
<b>DOTARE TEHNICĂ</b>	<b>24</b>
<b>CERTIFICAT CARGO</b>	<b>26</b>



Când vine momentul:  
**LIVRARE** NOCTURNĂ SILENȚIOASĂ

**Silence is golden!**

Just in time – asta înseamnă adesea: livrare nocturnă! Să fii rapid, proaspăt, punctual la începutul vânzării. Așa suntem obișnuiți. Dar pentru unul mămă, pentru altul ciumă? Ușile CARGO sunt extrem de line și își aduc astfel contribuția efectivă la reducerea zgomotului. Ușile sunt adecvate pentru omologarea PIEK.

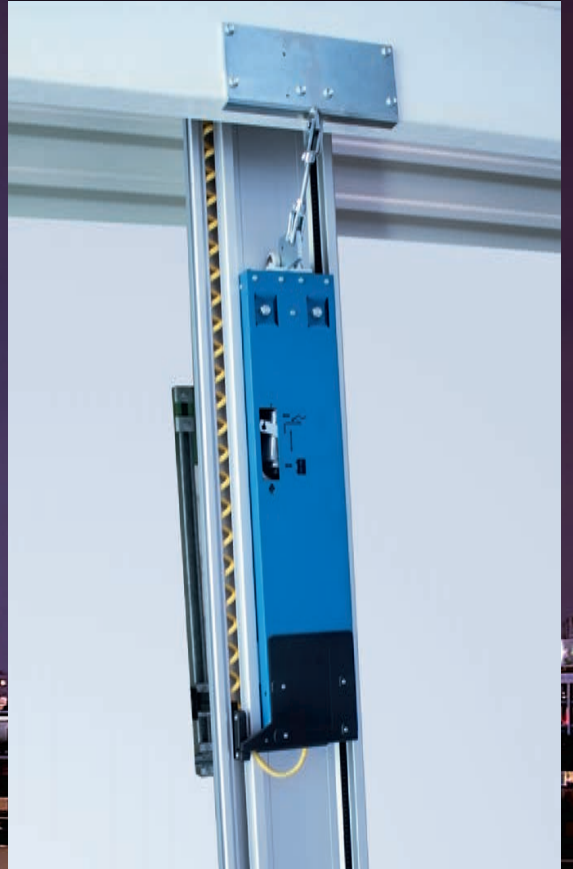
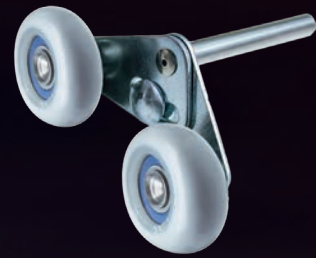



## SERVICII FARMACEUTICE

### Mărfuri sănătoase – non-stop

Condițiile de transport rapide și sigure asigură o desfășurare fără perturbări în cadrul depozitării și distribuirii de produse farmaceutice în cea mai mare parte sensibile.

Ușile sunt predestinate pentru transporturile farmaceutice.



## Secțiuni CT-67





# MĂRFURI VALOROASE TRANSPORT SIGUR ANTI-EFRAȚIE

**Toate lucrurile dumneavoastră de preț...**

Ușile CARGO dețin tehnici de ultimă generație:  
Concepte de siguranță ingenioase și producție la cel mai  
înalt nivel.  
Variantele CT-60 și Alu certificate





# Secțiuni CT-67





# MĂRFURI REFRIGERATE TRANSPORT MĂRFURI PROASPETE

Pe tărâmul acestor cinci colegi aproape că nu trebuie să ne bate capul pentru prospețime, în alte regiuni este nevoie de tehnologii ingineresti.



# Secțiuni CT-60



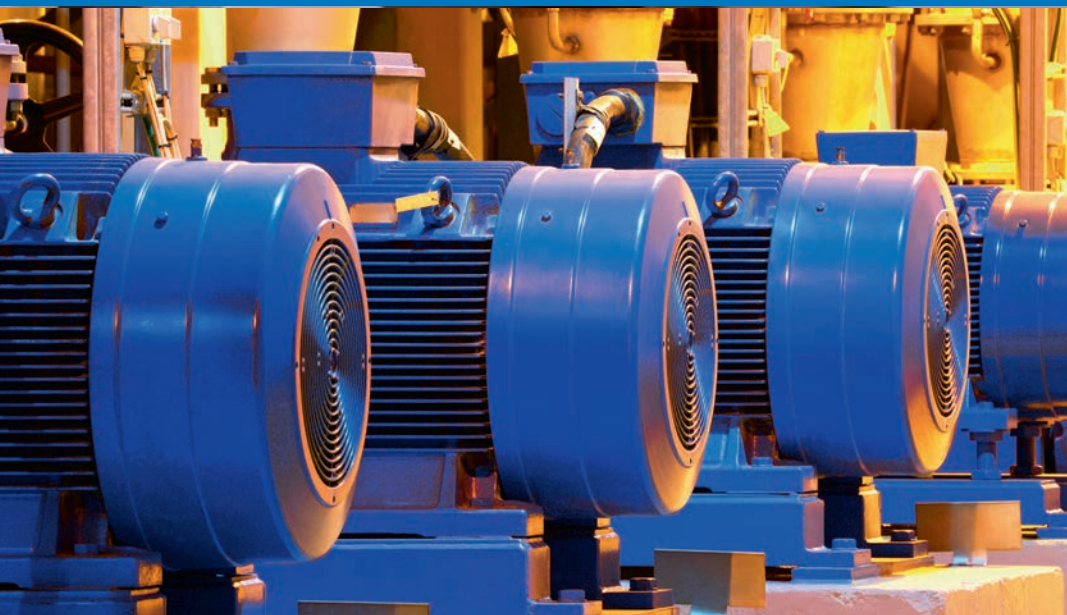

## CERTIFICAT CODE XL

Ușile CARGO certificate CODE XL au fost dezvoltate pentru transportul deosebit de exigent de obiecte grele. Dispoziții legale – cu o siguranță de încărcare a ușii peste 8,1 t sunt certificate.

**8,1 t**

Code XL

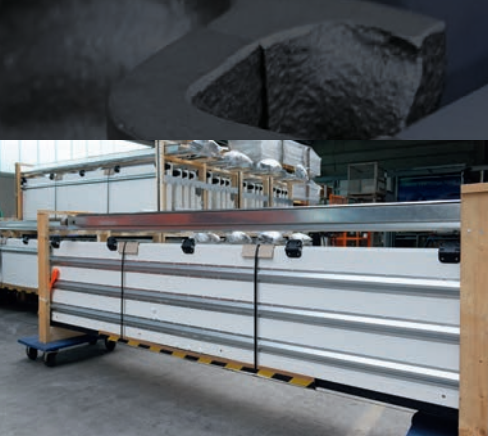

**ECO** LOGISTIC

**EFICIENT** ENERGETIC



## ECOLOGIE – NIMIC MAI MULT DOAR ÎN STELE

Produse sustenabile din punct de vedere ecologic încă de la început

Politica de mediu, sănătate și muncă a Grupului Novoferm alcătuiește un sistem de management închis și este obligatorie pentru toți angajații și procesele. Depunem eforturi în vederea îmbunătățirii continue a protecției mediului și prevenirii impactului asupra mediului. În această privință ne implicăm clienții și furnizorii în scopul asigurării unui nivel cât mai ridicat de sustenabilitate. În cadrul dezvoltării și producției avem în vedere utilizarea materialelor reciclabile în scopul reducerii emisiilor de CO<sub>2</sub> și evitării materialelor periculoase. În acest mod rezultă produse sustenabile din punct de vedere ecologic încă de la început.

# PERSPECTIVE SIEBAU

Succesul mărcii are numeroase motive bune:  
Dezvoltarea conceptelor convingătoare de produs, instalații  
de producție ultra-moderne, standarde de calitate fără  
compromis.







# INFORMAȚIA ÎNSEAMNĂ COMUNICARE





# ÎNCREDEREA CLIENȚILOR

**VAK**



KAROSSERIEWERK  
**MEYER**  
GÖTTINGEN

**SCHWARZMÜLLER**

 **WEKA**  
Fahrzeugbau

**DOLL**

 **GK GRÜNENFELDER**  
creating mobility



ERRE.B srl







# DOTARE TEHNICĂ



A cincea generație de role alergătoare cu înveliș exterior din 2 componente.  
Varianta 2022



Rolă tandem nouă, varianta 2022



Fereastră oțel inoxidabil, geam dublu,  
disponibil opțional



Închidere interioară cu mâner tip  
ciupercă încorporat



Închidere interioară nouă,  
vedere din interior





Opritor mecanic, disponibil opțional



Variantă CODE XL



Compartiment Catering, CT-39



Ușă din aluminiu



Vedere din interior compartiment Catering



Ușă CARGO CT-67 vedere din interior

# CERTIFICAT CARGO

**TUV NORD Confirmation**  
for a roller door

Product name: Cargo Tor 60CTAT Manufacturer: Novoferm Siebau GmbH  
Serial no.: 24705793 Address: Backswiese 23  
57223 Kreuztal/Suschhütten



**PIEK**

This device fulfills PIEK  
nighttime delivery standards  
< 60 dB(A)

place/date: Hannover, 2011-11-16  
tester: Volker Werner  
phone: +49 511 986 2027  
fax: +49 511 986 2233  
email: vwerner@tuv-nord.de

811 11 002 002

**TUV SAAR** Zertifikat 013919/1014 01

**Novoferm Siebau GmbH**  
Backswiese 23  
57223 Kreuztal

**ISO 9001:2008**

Entwicklung, Herstellung und Vertrieb von Carporten

Dieses Zertifikat ist gültig vom 07.08.2017 bis 14.08.2018.  
Die Aufrechterhaltung der Zulassungserfüllung erfolgt durch regelmäßige Überwachungsaudits. Die Reakkreditierungsfrist muss vor dem 15.07.2019 eingehalten werden.  
Ausgabe 3

Für diesen Zertifikatsausweis wurden mehrere Zertifikatsausweise zugewiesen.  
Hauptzertifikat Nr. 013919/1014 01

**SGS** **DÜKS**

811 11 002 002

**PRÜFERBERICHT**

**SKG-IKOB**

Berichtsnummer: 1481238  
Datum Prüfung: 4. März 2015  
Datum Bericht: 26. September 2015  
Auftraggeber: Novoferm Siebau GmbH  
Backswiese 23  
57223 Kreuztal  
Deutschland

Umfang Bericht: Dieser Bericht umfasst 21 Seiten (einschließlich Anlagen)

Beruf: Einweisung der Einbaueinrichtung gemäss EN 1827:2011 & NEN 9996:2012 eines Cargo Tor mit Abmessungen: B x H: 2330 x 2400 mm hergestellt aus dem Profilsystem Neuluxform

Bezeichnung: Cargo Tor 60 EDH  
Prüfer: C. Walzer, M. Pates, M. Rhoberger, J.G. van de Wiering  
Prüfzettel: J. T. Pates  
Schlüsselwörter: Das Cargo Tor von Novoferm Siebau GmbH nach dem Profilsystem Eigenanfertiger erfüllt die Einbaueinrichtung gemäss EN 1827:2011 & NEN 9996:2012

811 11 002 002

**Letter of Conformity**

Actuali Doorfit Systems B.V. Tel: +31337074889  
Prinsengr 51, Fax: +31336508877  
3821AP Amersfoort www.doorfitsystems.nl  
Netherlands info@doorfitsystems.nl

Actuali Doorfit Systems B.V. hereby certify under sole responsibility conformity of the product

Article number: DL-4 / DL-4-Line  
Type: Doorfit  
Under Trade name: Doorfit  
Imported through: Actuali Doorfit Systems B.V

With the essential requirements of the following EC Directives:

2004/104/EC	2004	Directive for motor vehicles and electrical/electronic sub assemblies (ESAs) related to the radio interference (electromagnetic compatibility) of vehicles, (including the old version 72/45/EEG).
CSRP 25	2002	Emission - Vehicles, Boats and Internal Combustion Engine powered Vehicles (for protection of on board receivers).
ISO 7637-2+1	2008	Transient immunity
ISO 11452	2008	RF electromagnetic field immunity general
ISO 11452-3	2003	Transverse electromagnetic mode (TEM) cell

Testreport generated by KEMA quality B.V. - Amhem nr. 2130144-0501-QUA/EMC

Awarded on: 20 Juli 2012

Managing director: T.G.H. Houben



**PRÜFERBERICHT**  
**TESTREPORT**  
Nr.No. 34527

**Anerkannte Prüfstelle**  
Beauftragter: Wärmegedämmtes Rolltor  
Hersteller: Novoferm Siebau GmbH  
Hessstraße 5  
57223 Kreuztal  
Auftraggeber: Novoferm Siebau GmbH  
Hessstraße 5  
57223 Kreuztal

**Auftragsetzung**  
Scope of the order: Bestimmung des zusätzlichen Wärmestromes durch ein wärmegedämmtes Rolltor in Anlehnung an die A17P-Überspannungen, Anlage 1, Anhang 2, Ziffer (7) - (15)  
Dimensionierung der zusätzlichen Rolltür durch ein formal insulated roller shutter according to the A17P agreement, annex 1, appendix 2, paragraph (7) - (15)

**Eingabedatum**  
Date of delivery: 28.09.2009

**Prüfzeitraum**  
Period of testing: 28.09.2009 - 01.10.2009

**Prüfungsort**  
Place of test: München

**Prüfungsmethode**  
Method of test: Übereinkommen über die internationale Beförderung leicht veränderlicher Lastenmittel und über die besonderen Beförderungsmittel, die für diese Beförderungen zu verwenden sind (A17P) Übereinkommen über die internationale Beförderung leicht veränderlicher Lastenmittel und über die besonderen Beförderungsmittel, die für diese Beförderungen zu verwenden sind (A17P)

811 11 002 002

**TUV NORD Mobilität GmbH & Co. KG**

Zertifikat über Prüfungen zur Ladungsicherung und Festigkeit von Fahrzeugaufbauten nach DIN EN 12642, Anhang A (2007-01) und DIN EN 283 (1991-08)

8114379533-PB1-Z1

Hersteller: Novoferm Siebau GmbH  
Backswiese 23  
57223 Kreuztal

Objekt: Sandwich Rolltor  
Typ: Cargo Tor 39 XL

Max. Nutzlast in [kg]: 27.000 (rückwärtiger Einbaue)

Max. Achsabmessungen B x H in [mm]: 2.400 x 2.750

**2 Angaben zur Ausstattung**  
Nachgewiesene Prüfkriterie (DIN EN 12642, Anhang A) 8.100 daN  
Rolltor aus Sandwichprofilen mit innen verschraubten Typ Cargo Tor 39 XL

Der Zustand des Fahrzeugaufbaus ist vom Fahrzeughersteller/Fahrzeugträger gem. VDI 2700 jährlich durch eine befähigte Person zu überprüfen und gemäß Herstellerangaben zu dokumentieren.

**3 Zusammenfassung**  
Das vorstehend beschriebene Rolltor erfüllt die Anforderungen der DIN EN 12642 Code XL für eine Nutzlast bis zu 27.000 kg (rückwärtiger Einbau 0,3 x P). Die Anforderungen der DIN EN 283 bis zu einer Nutzlast von 20.250 kg sind ebenfalls erfüllt (Steward 5,4 x P).

TUV NORD Mobilität GmbH & Co. KG  
Prüf- Institut für Fahrzeugtechnik und Mobilität  
Neuluxform Siebau GmbH, Backswiese 23, 57223 Kreuztal  
Geschäftsbereich Hannover  
Fachgruppen Ladungsicherung

Hannover, 02.03.2017  
Kreuztal, 28.03.2017

Uwe Marler  
Frank J. Audebert

Dieses Zertifikat ist nur gültig in vollständiger Form. Es basiert auf dem zugrundeliegenden Prüfbericht und unterliegt technischen und/oder gesetzlichen Änderungen. 8114379533-PB1-Z1 Seite 1 von 1

**TUV NORD Mobilität GmbH & Co. KG**

Zertifikat über Prüfungen zur Ladungsicherung und Festigkeit von Fahrzeugaufbauten nach DIN EN 12642, Anhang A (2017-03) und DIN EN 283 (1991-08)

8115251035-PB1-Z1

Hersteller: Novoferm Siebau GmbH  
Backswiese 23  
57223 Kreuztal  
info@novoferm.com  
07710 2030

Objekt: Sandwich Rolltor  
Typ: Cargo Tor 39 XL

Max. Nutzlast in [kg]: 27.000 (rückwärtiger Einbau)

Max. Achsabmessungen B x H in [mm]: 2.400 x 2.750

**2 Angaben zur Ausstattung**  
Nachgewiesene Prüfkriterie (DIN EN 12642, Anhang A) 8.100 daN  
Rolltor aus Sandwichprofilen mit innen verschraubten Typ Cargo Tor 39 XL mit oder ohne Verschraubung

Der Zustand des Fahrzeugaufbaus ist vom Fahrzeughersteller/Fahrzeugträger gem. VDI 2700 jährlich durch eine befähigte Person zu überprüfen und gemäß Herstellerangaben zu dokumentieren.

**3 Zusammenfassung**  
Das vorstehend beschriebene Rolltor erfüllt die Anforderungen der DIN EN 12642 Code XL für eine Nutzlast bis zu 27.000 kg (rückwärtiger Einbau 0,3 x P). Die Anforderungen der DIN EN 283 bis zu einer Nutzlast von 20.250 kg sind ebenfalls erfüllt (Steward 5,4 x P).

TUV NORD Mobilität GmbH & Co. KG  
Prüf- Institut für Fahrzeugtechnik und Mobilität  
Neuluxform Siebau GmbH, Backswiese 23, 57223 Kreuztal  
Geschäftsbereich Hannover  
Fachgruppen Ladungsicherung

Hannover, 09.01.2018  
Kreuztal, 11.01.2018

Uwe Marler  
Frank J. Audebert

Dieses Zertifikat ist nur gültig in vollständiger Form. Es basiert auf dem zugrundeliegenden Prüfbericht und unterliegt technischen und/oder gesetzlichen Änderungen. 8115251035-PB1-Z1 Seite 1 von 1

**TUV NORD Mobilität GmbH & Co. KG**

Zertifikat über Prüfungen zur Ladungsicherung und Festigkeit von Fahrzeugaufbauten nach DIN EN 12642, Anhang A (2007-01) und DIN EN 283 (1991-08)

8110289809-PB1-Z1

Hersteller: Novoferm Siebau GmbH  
Backswiese 23  
57223 Kreuztal

Objekt: Aluminium Rolltor  
Typ: Au-Cargo Tor

Max. Nutzlast in [kg]: 27.000 (rückwärtiger Einbau)

Max. Achsabmessungen B x H in [mm]: 2.400 x 2.750

**2 Angaben zur Ausstattung**  
Nachgewiesene Prüfkriterie (DIN EN 12642, Anhang A) 8.100 daN  
Rolltor aus Aluminiumprofilen Typ Au-Cargo Tor

Der Zustand des Fahrzeugaufbaus ist vom Fahrzeughersteller/Fahrzeugträger gem. VDI 2700 jährlich durch eine befähigte Person zu überprüfen und gemäß Herstellerangaben zu dokumentieren.

**3 Zusammenfassung**  
Das vorstehend beschriebene Rolltor erfüllt die Anforderungen der DIN EN 12642 Code XL für eine Nutzlast bis zu 27.000 kg (rückwärtiger Einbau 0,3 x P). Die Anforderungen der DIN EN 283 bis zu einer Nutzlast von 20.250 kg sind ebenfalls erfüllt (Steward 5,4 x P).

TUV NORD Mobilität GmbH & Co. KG  
Prüf- Institut für Fahrzeugtechnik und Mobilität  
Neuluxform Siebau GmbH, Backswiese 23, 57223 Kreuztal  
Geschäftsbereich Hannover  
Fachgruppen Ladungsicherung

Hannover, 15.07.2013

Uwe Marler  
Name: Dirk Göttinger

Dieses Zertifikat ist nur gültig in vollständiger Form. Es basiert auf dem zugrundeliegenden Prüfbericht und unterliegt technischen und/oder gesetzlichen Änderungen. 8110289809-PB1-Z1 Seite 1 von 1

## Necesar de spațiu: Uși CARGO cu sistem de echilibrare

Pentru determinarea dimensiunilor corecte pentru ușă vă rugăm să completați câmpurile marcate.

### Secțiune orizontală

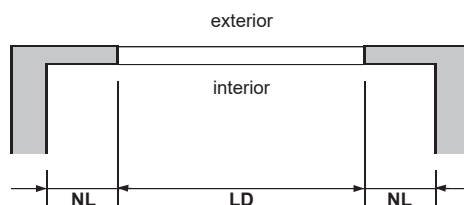

### Secțiune verticală

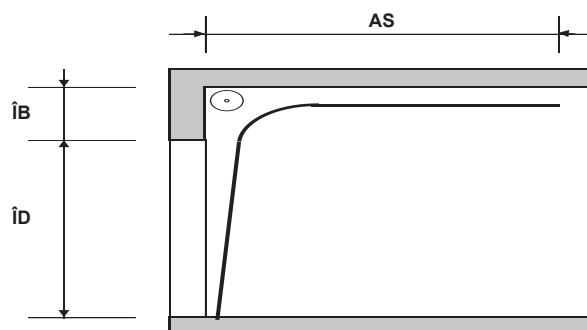

NL = Necesari opritor Lateral	NL = min. 60 mm
LD = Lățime Deschidere	ÎB = min. 200 mm
ÎB = Înălțime Bordură	AS = ÎD + 120 mm
ÎD = Înălțime Deschidere	Lungimea șinelor de rulare orizontale ÎD + 1100 mm
AS = Adâncime Spațiu de depozitare	

Utilizare în

Compartiment frigorific

Compartiment pentru produse proaspete

Încărcătură uscată

Blocare

Exterior

Interior

Interior cu mâner rotativ exterior

Nuanță de culoare \_\_\_\_\_

Observații/particularități

\_\_\_\_\_

Eu/Noi vă rog/rugăm să îmi/ne transmiteți informații suplimentare

Nume \_\_\_\_\_ Telefon \_\_\_\_\_

Compania \_\_\_\_\_ Telefon mobil \_\_\_\_\_

Str. \_\_\_\_\_

Cod poștal/localitate \_\_\_\_\_

Vă rugăm să trimiteți la  
info@siebau-cargo.com  
www.siebau-cargo.com



# NE BUCURĂM SĂ NE REVEDEM



**Novoferm Siebau GmbH**

D-57223 Kreuztal

Tel. +49 27 32 202-260

Fax +49 27 32 202-291

**[info@siebau-cargotore.com](mailto:info@siebau-cargotore.com)**

**[www.siebau-cargotore.com](http://www.siebau-cargotore.com)**